

Jane A. Stickle, Sampler Quilt C-01

Jane's Block...



My Block...



C01...

Difficulty - Very Easy

Paper Foundation

Number of Pieces = 13

This one is VERY EASY, it starts out as a 'square in a square' and ends up as 'courthouse steps'. The fabric I used had a stripe in it, so that extra red border really isn't a border at all, just the stripe.

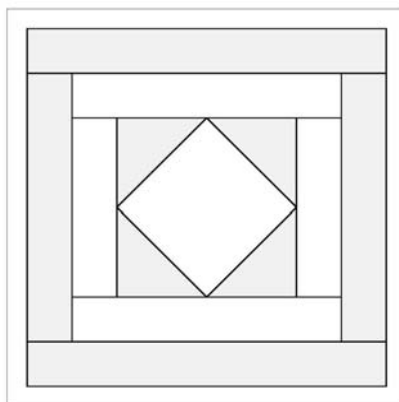

JAS C01

Drafted by Susan R. Gatewood, 1997

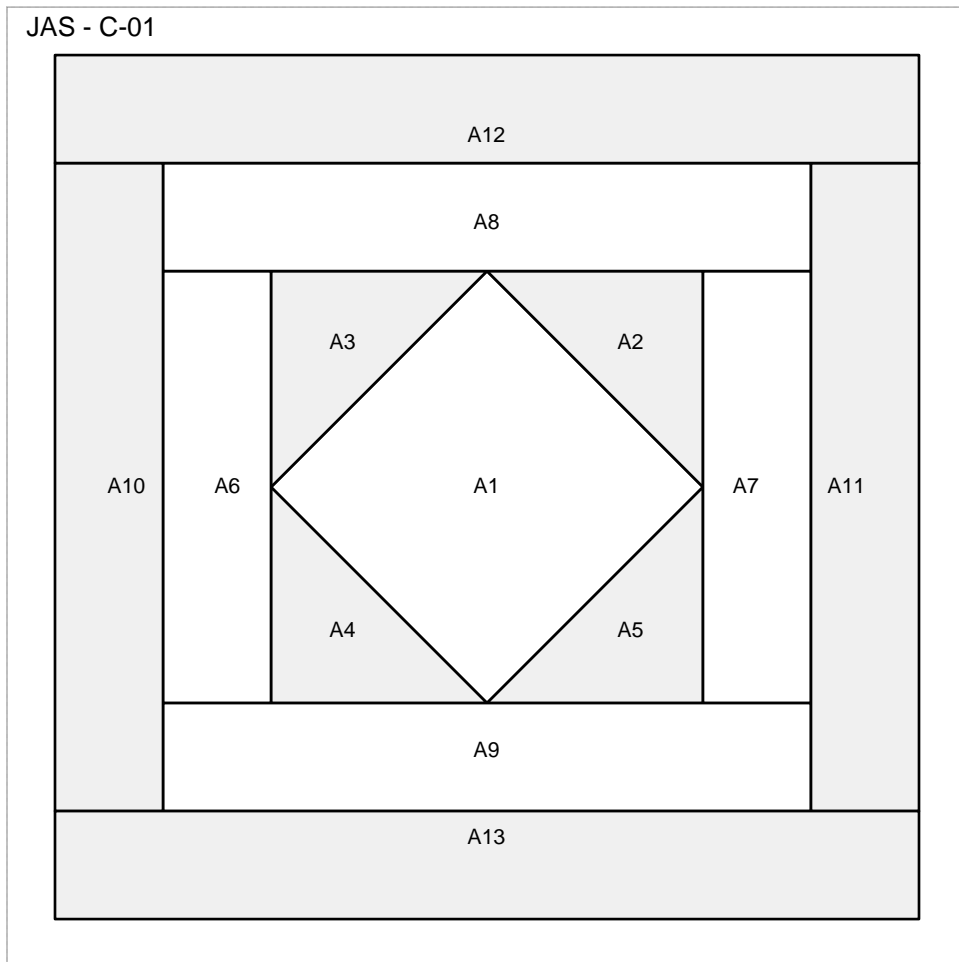

Jane's Block...



My Block...



C02...

Difficulty Medium

Paper Foundation

Number of Pieces = 19

This block could be done using the "Seminole piecing" method, but paper foundation makes it very easy to accomplish.

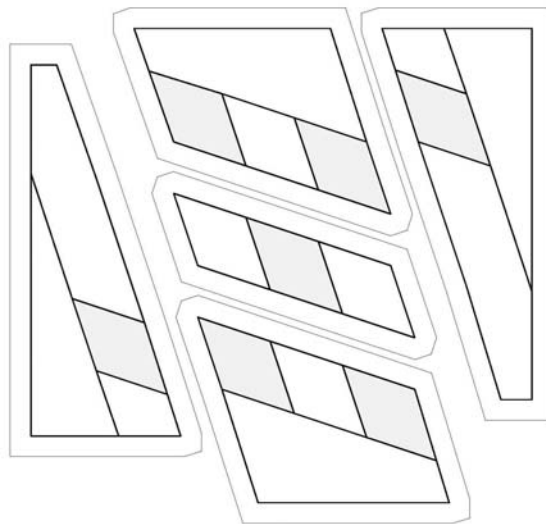

JAS C02

Drafted by Susan R. Gatewood, 1997

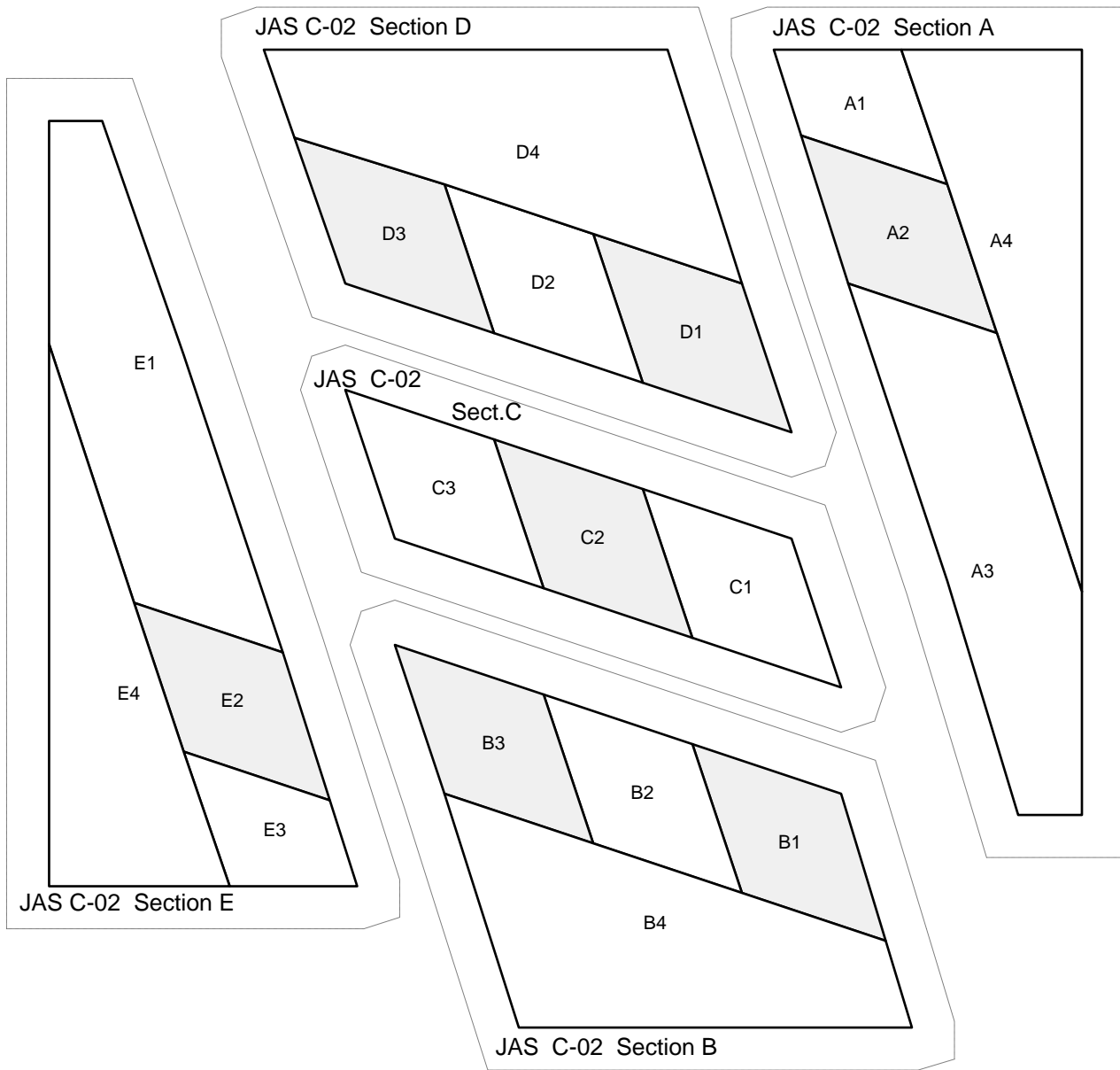

Jane A. Stickle, Sampler Quilt C-03

Jane's Block...



My Block...



C03...

Difficulty Easy

Paper Foundation

Number of Pieces = 25

This block is not hard and just think, you are getting 25 pieces to add to your count.

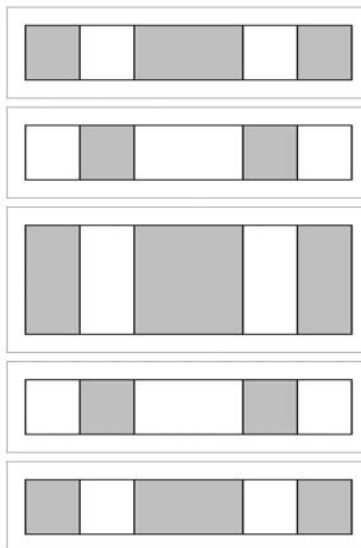

JAS C03

Drafted by Susan R. Gatewood, 1997

JAS C-03 Section A

A5	A4	A3	A2	A1
----	----	----	----	----

JAS C-03 Section C

C5	C4	C3	C1	C2
----	----	----	----	----

JAS C-03 Section D

D5	D4	D3	D1	D2
----	----	----	----	----

JAS C-03 Section E

E1	E2	E3	E4	E5
----	----	----	----	----

JAS C-03 Section B

B2	B1	B3	B4	B5
----	----	----	----	----

Jane A. Stickle, Sampler Quilt C-04

Jane's Block...

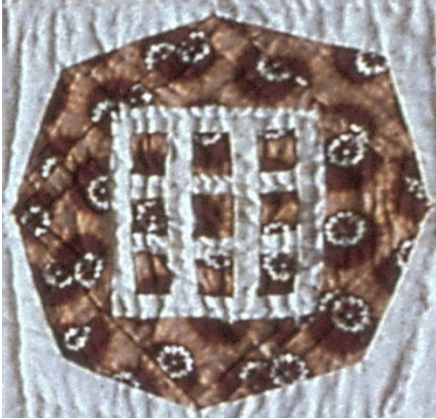

My Block...

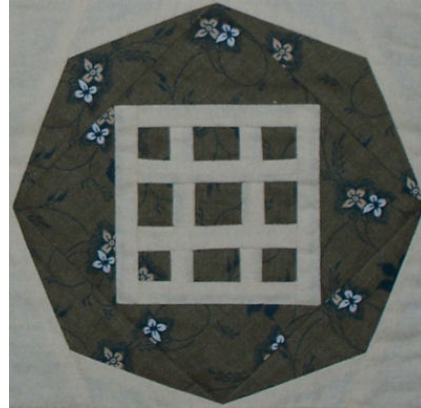

C04...

Difficulty Medium (only because there are a lot of pieces.)

Paper Foundation

Number of Pieces = 37

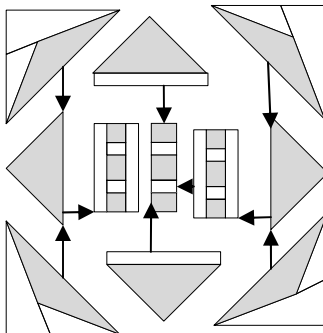

JAS C04

Drafted by Susan R. Gatewood, 1997

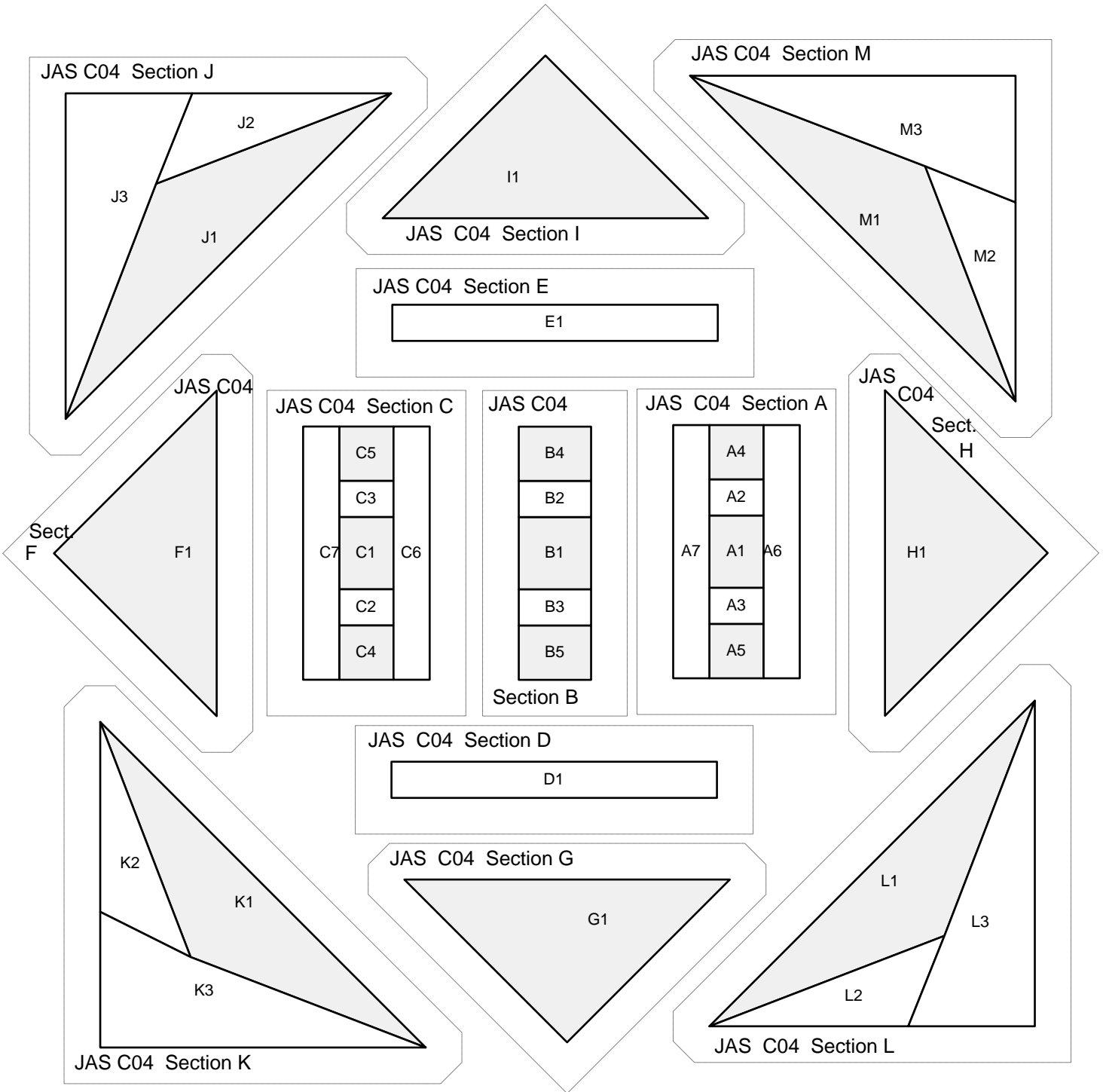

Jane A. Stickle, Sampler Quilt C-05

Jane's Block...

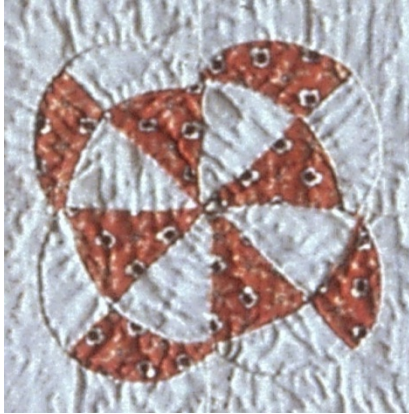

My Block...



C05...

Difficulty Medium Hard

Pieced and Appliqué

Number of Pieces = 20

Make two pinwheel blocks, from half square triangles. From one, cut out a circle, appliqué the circle to the second pinwheel block, staggering the colors. Make a four patch from the background material, using the template provided in the .pdf file, cut arcs from the four patch, trim inside curves and appliqué the four patch on top of the two pinwheel blocks. Square up the block to 5".



JAS - C05 Pinwheel Block

Make 2, Drafted by Susan R. Gatewood, 1997

Key Block (11/20 actual size)

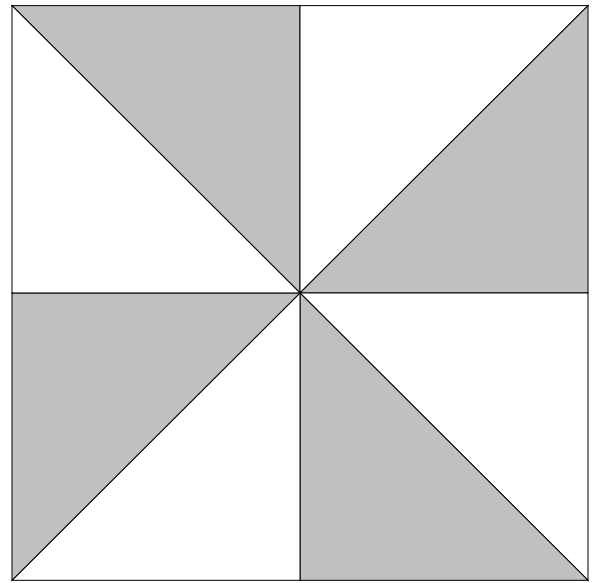
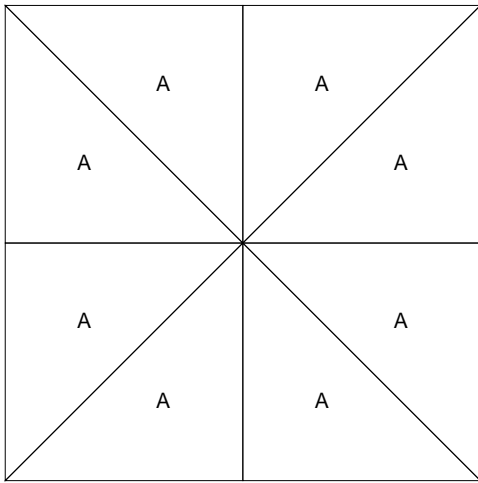

Cutting Diagrams

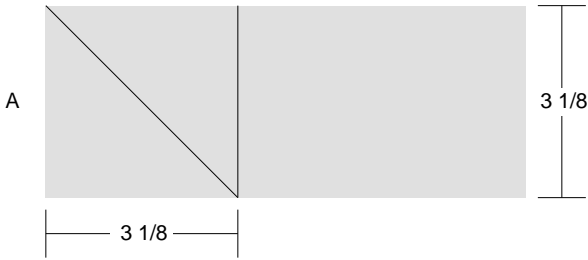

Patch Count



©Susan R. Gatewood, 1997-present

Key Block (77/100 actual size)

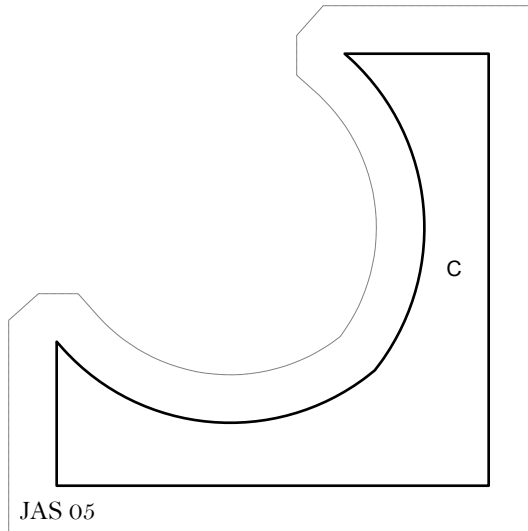
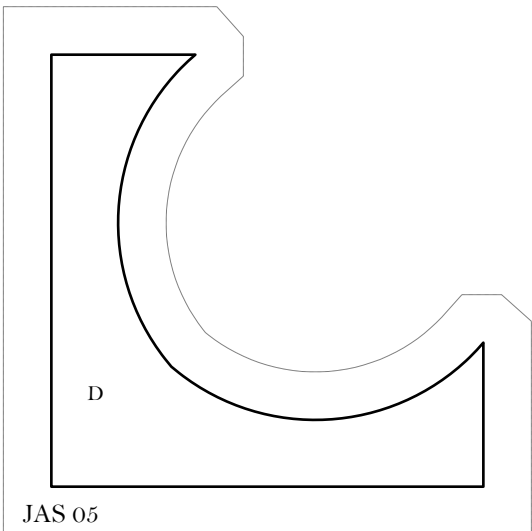
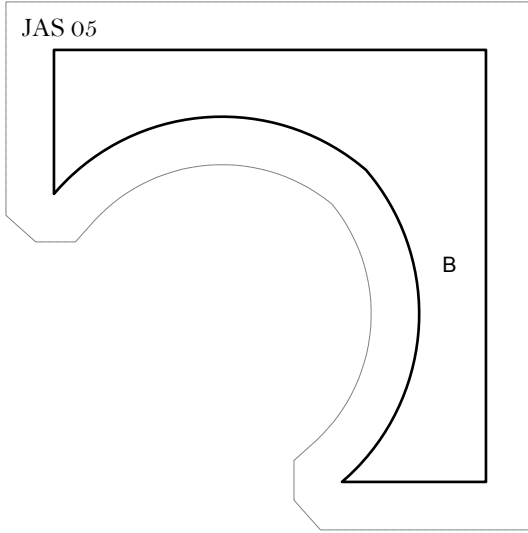
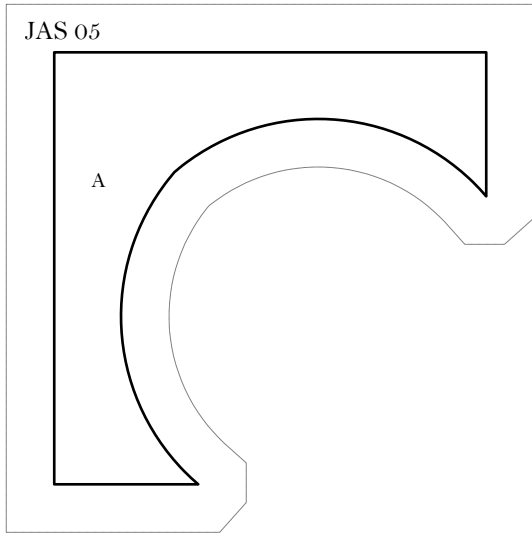
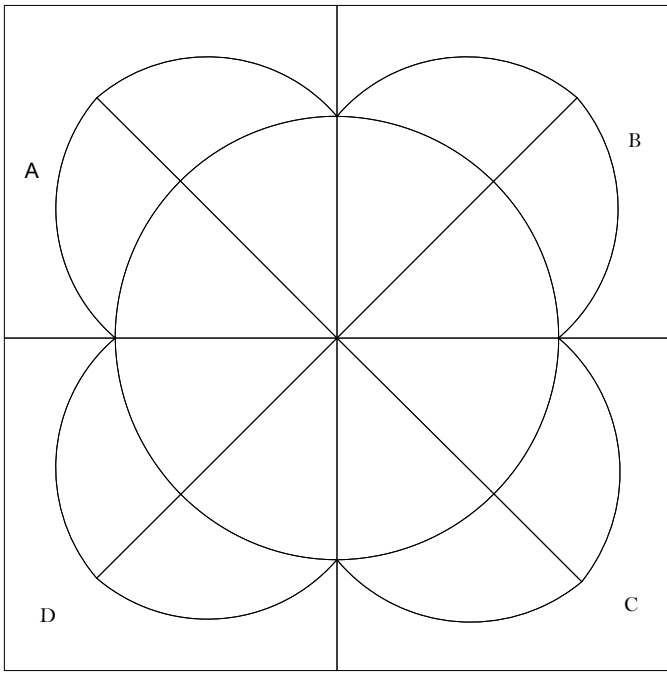

Jane A. Stickle, Sampler Quilt C-06

Jane's Block...



My Block...



C06...

Difficulty Medium Hard
(Only because of the curved pieces)

Pieced

Number of Pieces = 9

First sew the melon shapes to the corners, and then sew the pieced corners to the center. The arcs are fairly gentle, so they are not too hard to sew. It is easiest to match the center of the arc to the center of the concave corner and gently pull into shape as you sew.

Or, you could appliqué a circle to a square, then appliqué the center shape over the circle/square. Actually, that seems a little easier to me. Making this one a medium difficulty, with only three pieces.

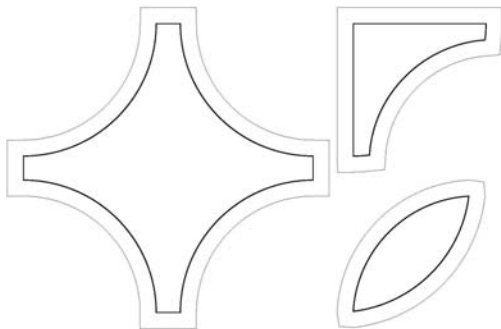

JAS C06

Key Block (77/100 actual size)

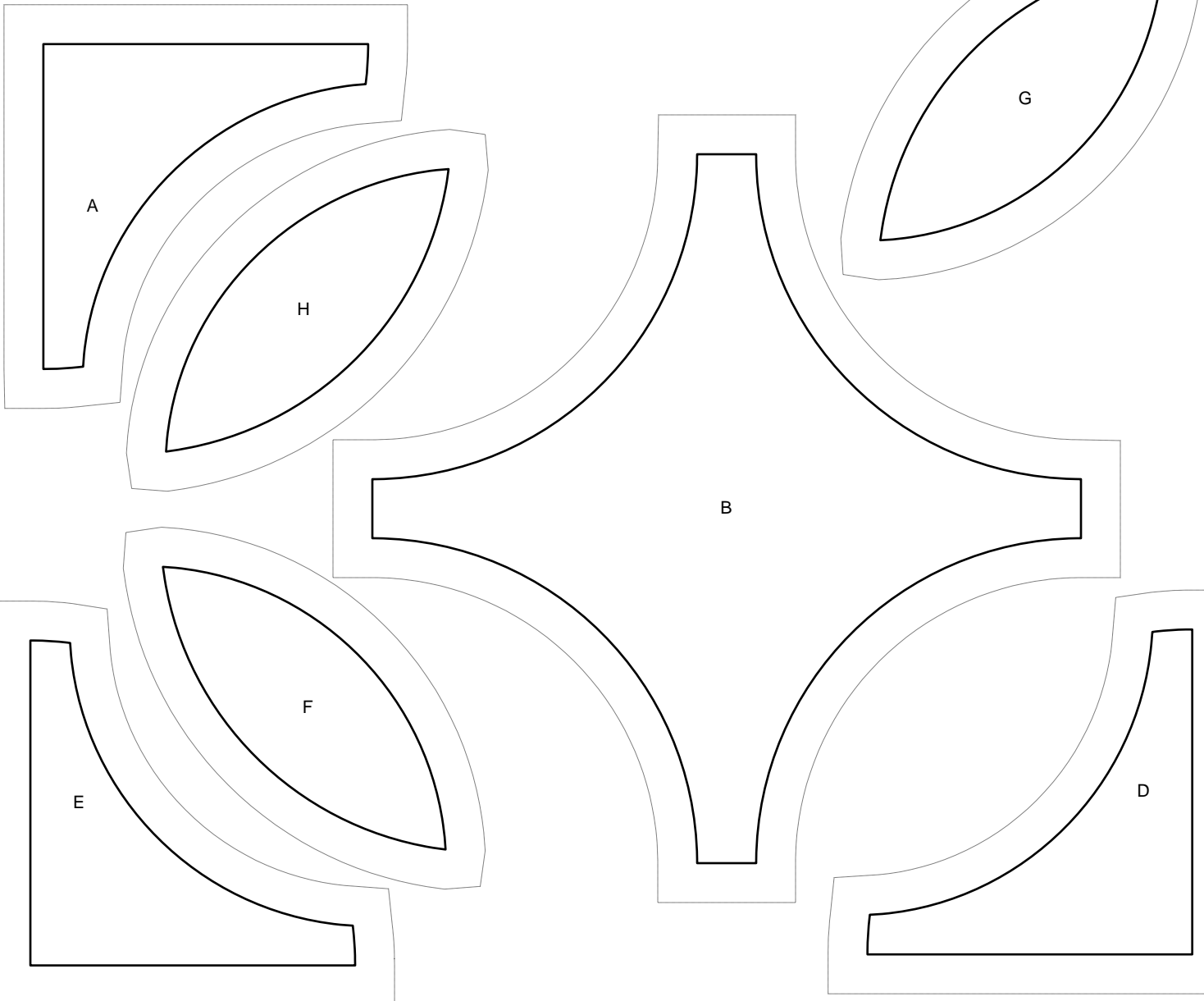
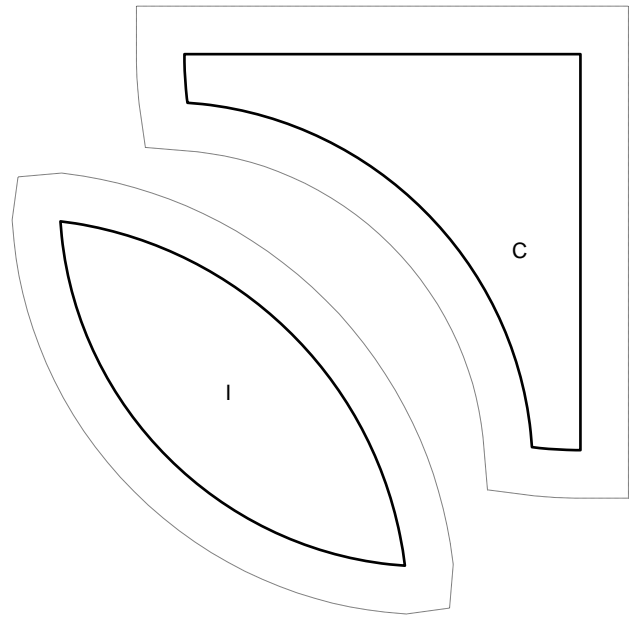
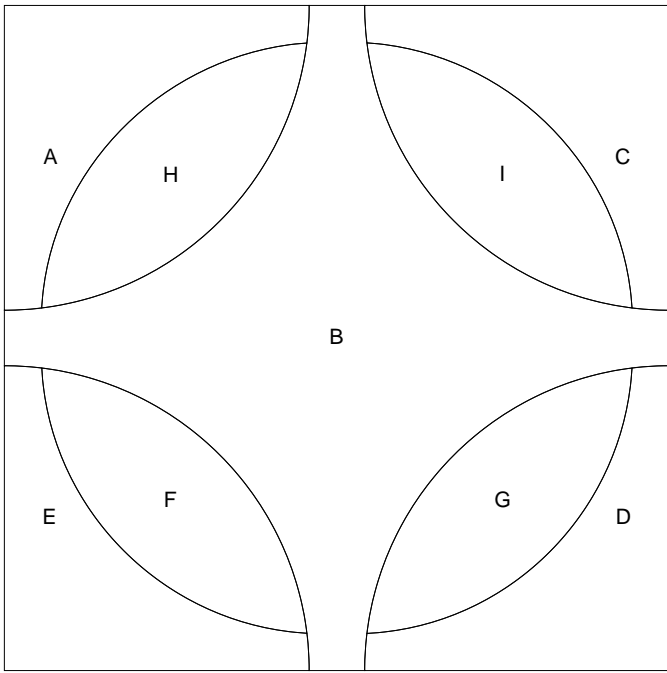

Jane A. Stickle, Sampler Quilt C-07

Jane's Block...



My Block...



C07...

Difficulty Medium Hard

Pieced and Appliquéd

Number of Pieces = 45

This block is a little hard because of the different sets that need to be put together in groups, before joining them to the other set, but just take each group at a time and try not to think of the whole block until you have gotten it all together. After piecing the block, appliqué a diamond in each corner.

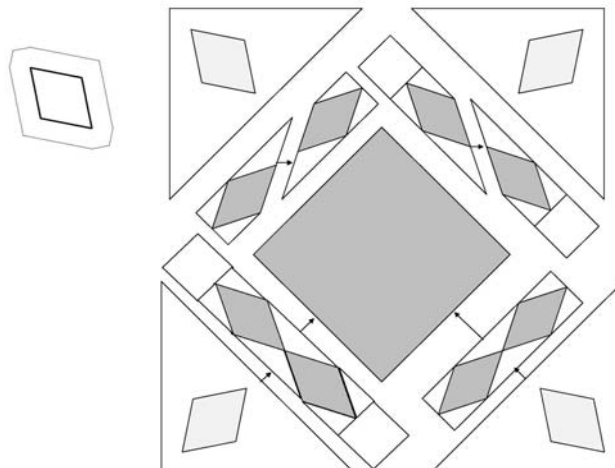

JAS C07

Drafted by Susan R. Gatewood, 1997

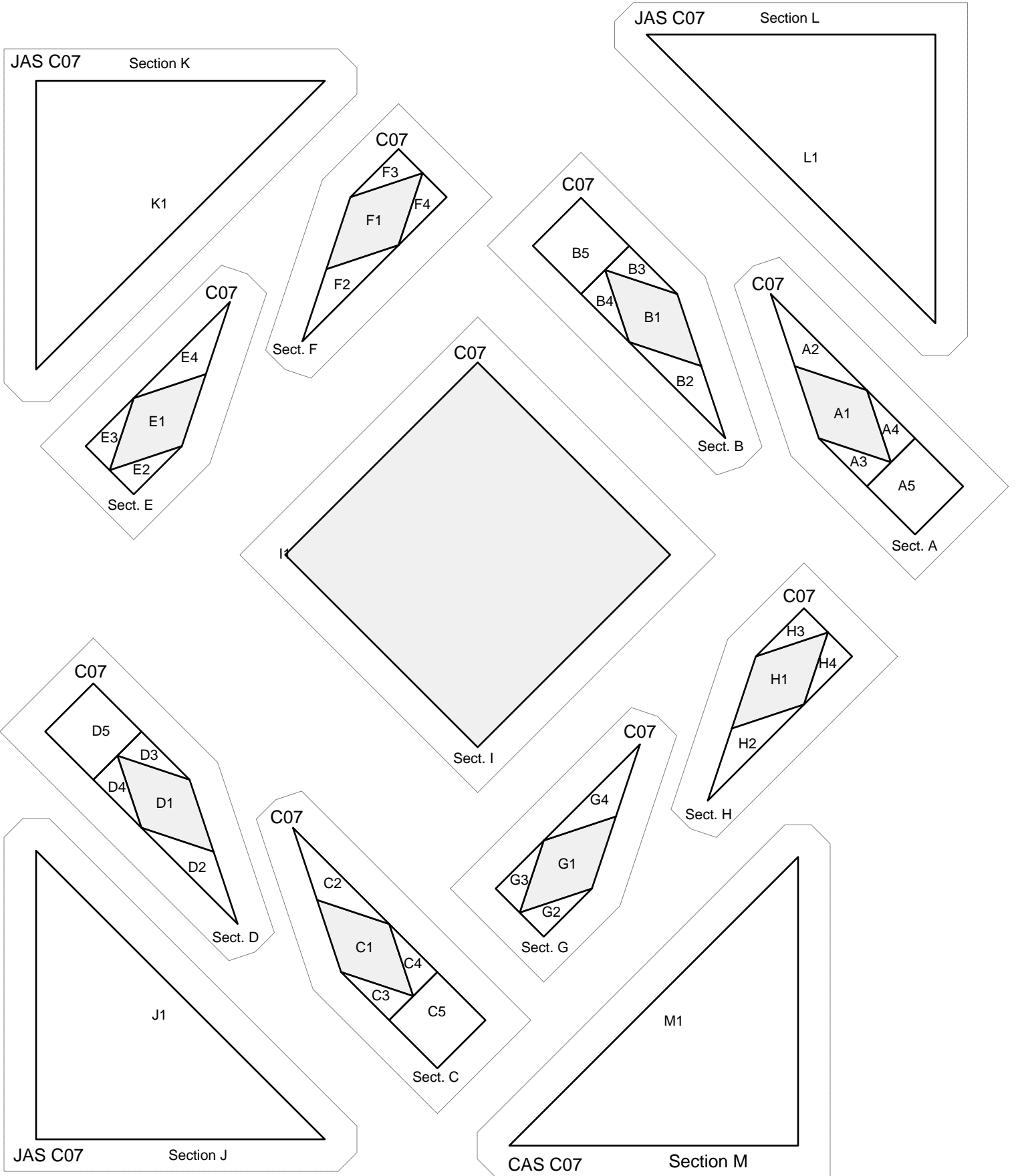

JAS C07

Diamond Template.

Key Block (77/100 actual size)

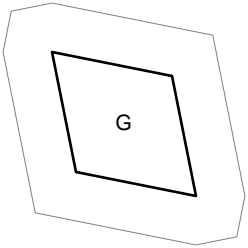
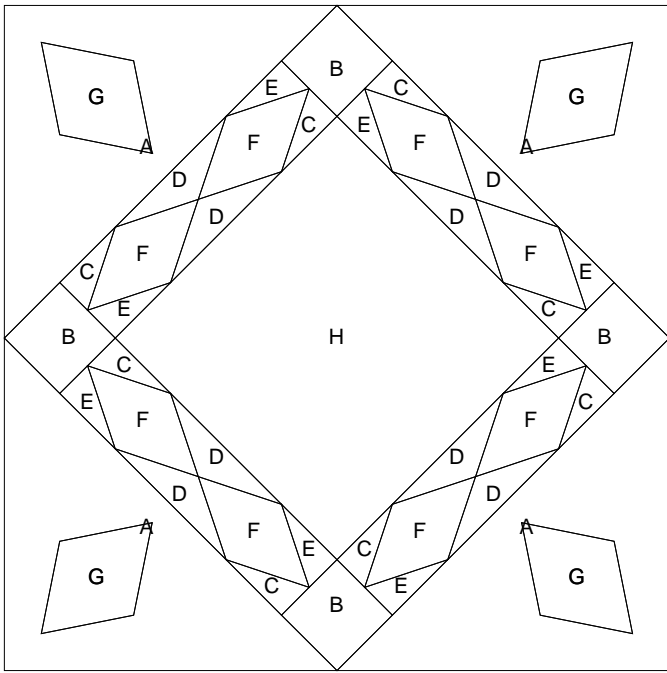

Jane A. Stickle, Sampler Quilt C-08

Jane's Block...



My Block...



C08...

Difficulty Medium

Foundation Pieced

Number of Pieces = 21

I consider this block a "medium", only because there are several sections that need to be grouped together before joining to a previous piece.

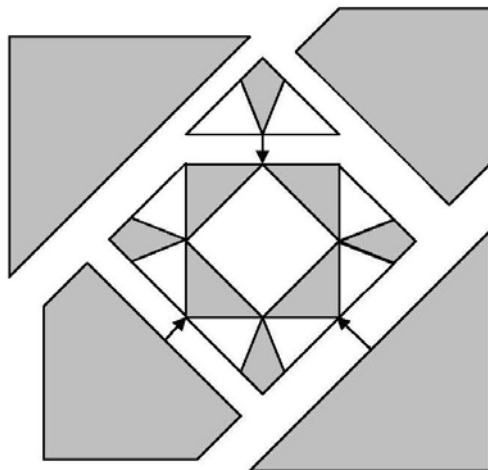

JAS C08

Drafted by Susan R. Gatewood, 1997

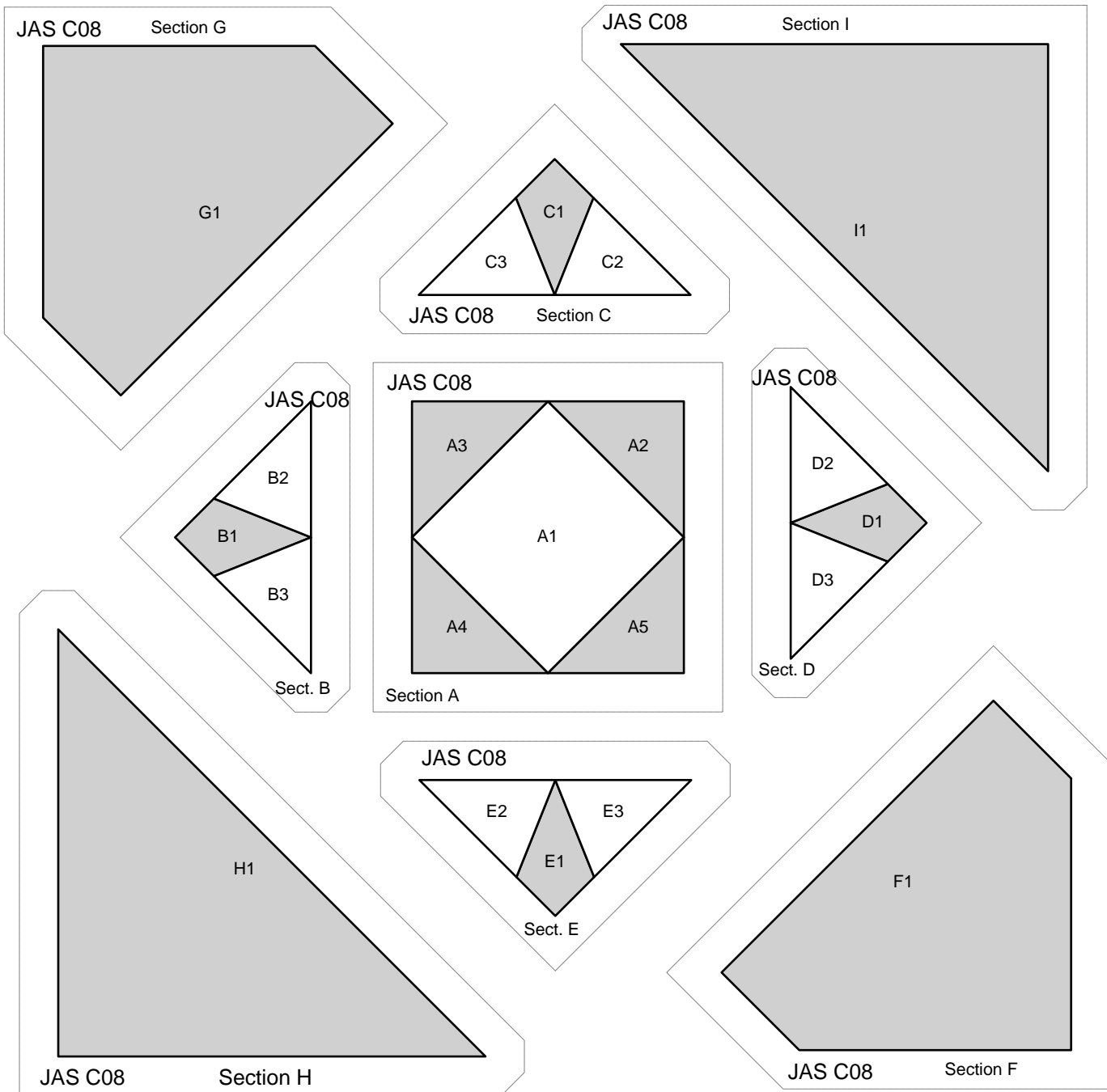

©Susan R. Gatewood, 1997-present

Jane A. Stickle, Sampler Quilt C-09

Jane's Block...



My Block...



C09...

Difficulty Easy

Appliqué

Number of Pieces = 5

If you look closely at Jane's block, you will see that she pieced her background by using four triangles. I chose to use just one piece for my background. If you decide to recreate yours the way Jane did, don't forget to change your number of pieces to 8.

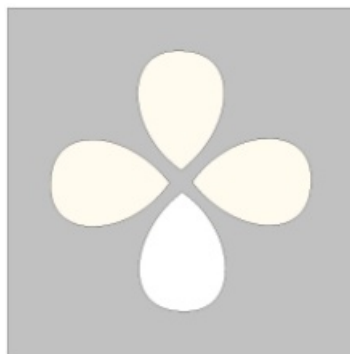

JAS C09

Drafted by Susan R. Gatewood, 1997

Key Block (77/100 actual size)

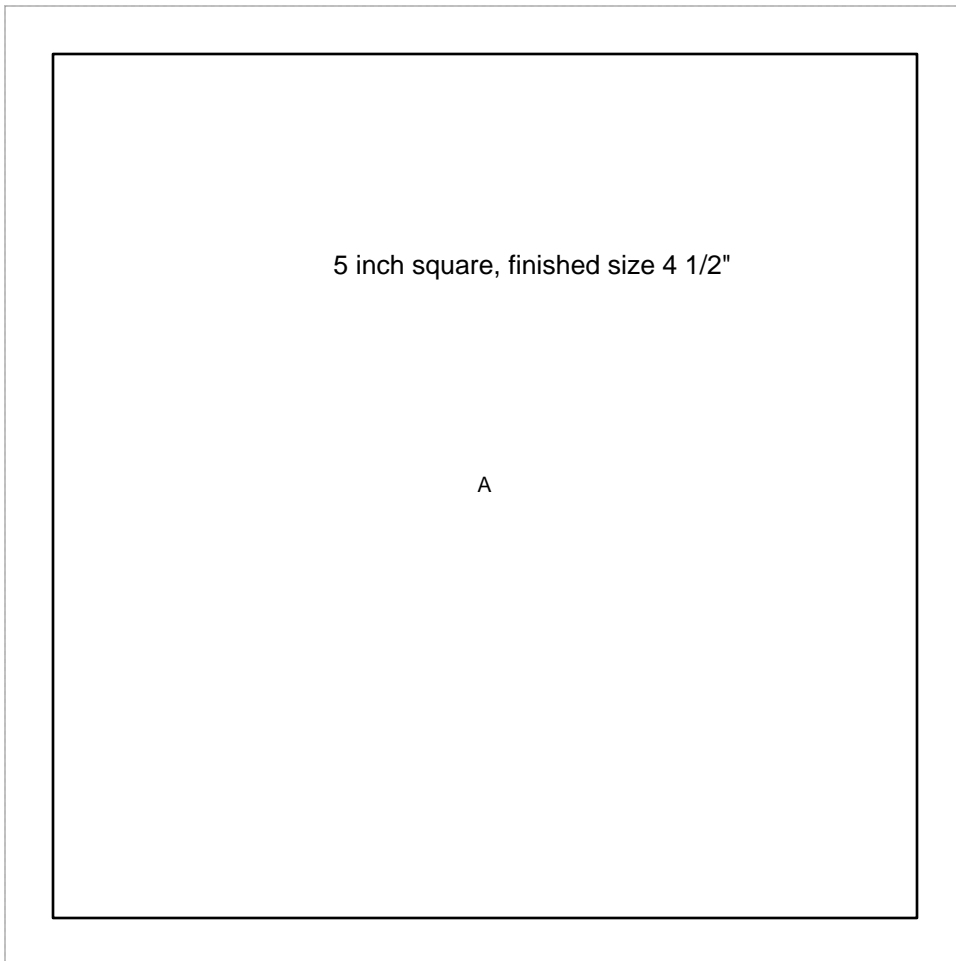
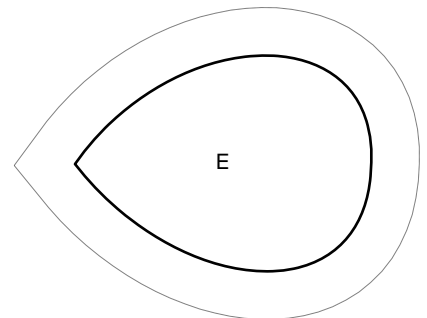
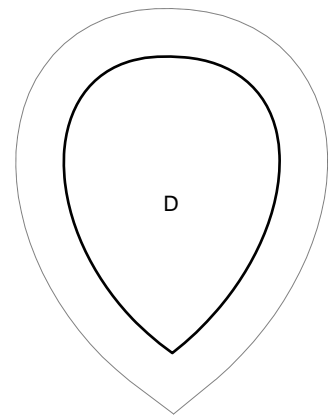
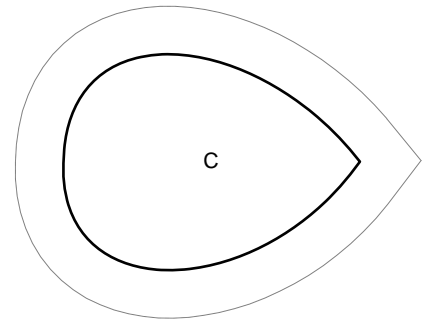
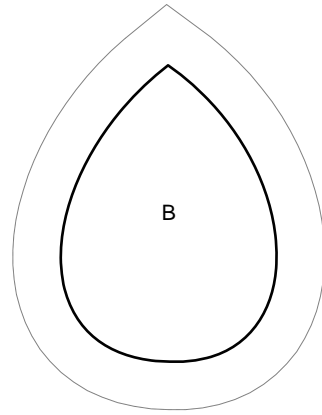
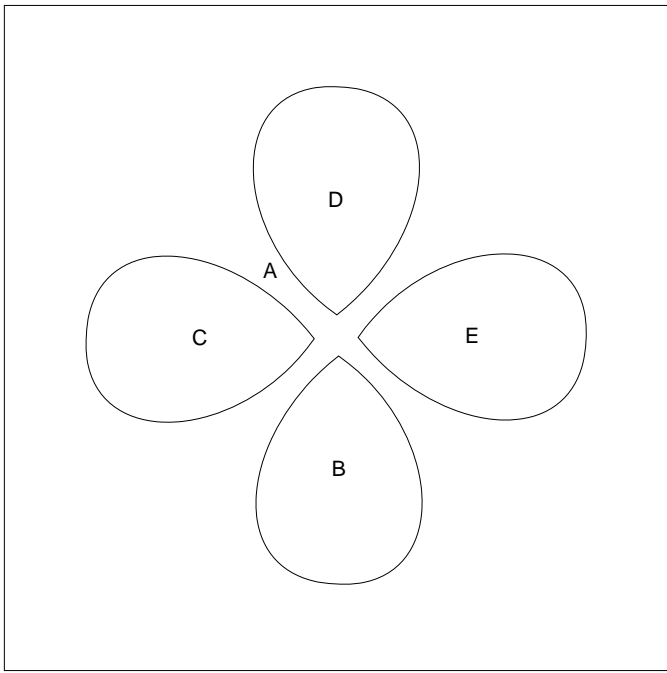

Jane A. Stickle, Sampler Quilt C-10

Jane's Block...

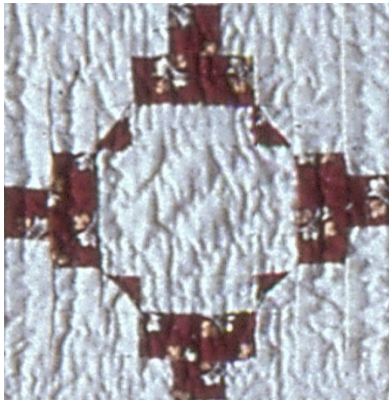

My Block...

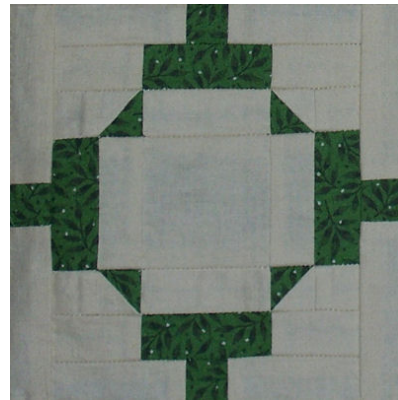

C10...

Difficulty Medium Hard

Paper Foundation

Number of Pieces = 37

This one has a lot of pieces, but just assemble each section, then assemble the sections together. When you break it down to individual sections, it will be a lot easier than you think. Try not to be overwhelmed by the whole block. The largest section 'A' has only five pieces.

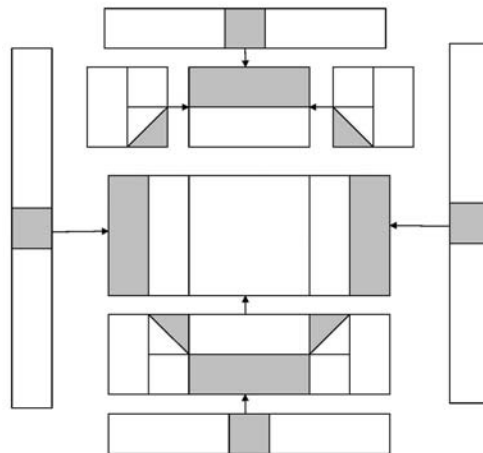

JAS C10

Drafted by Susan R. Gatewood, 1997

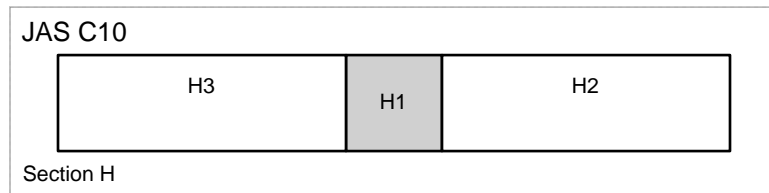
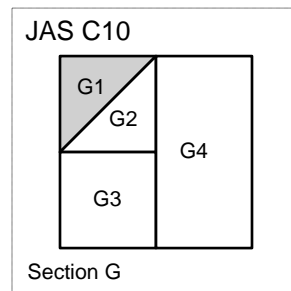
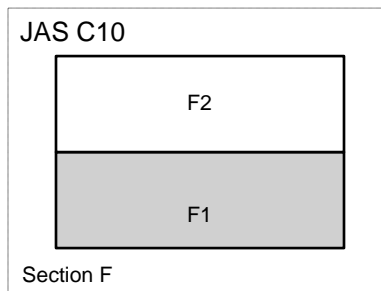
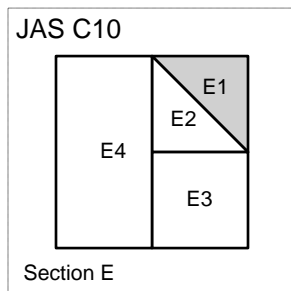
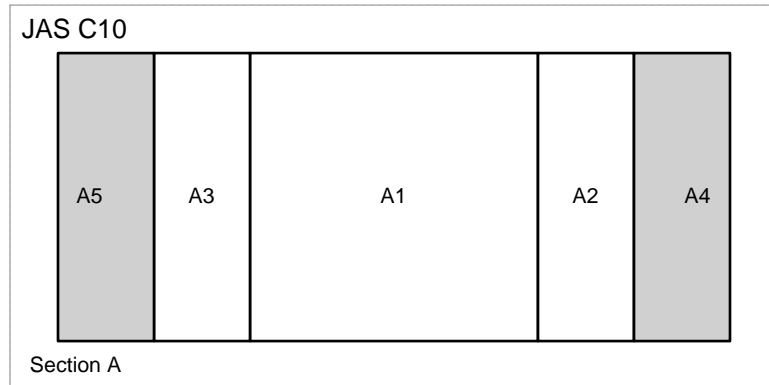
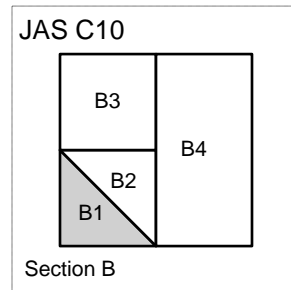
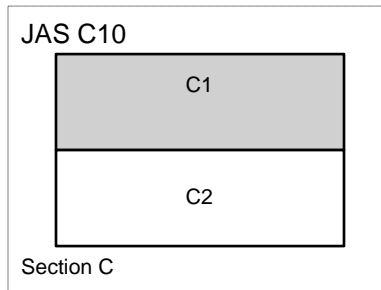
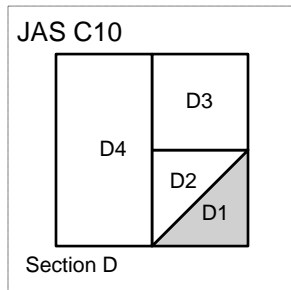
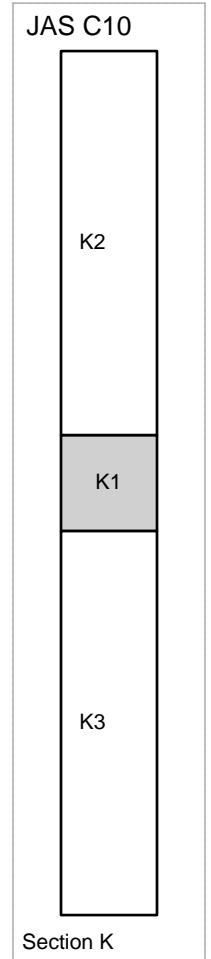
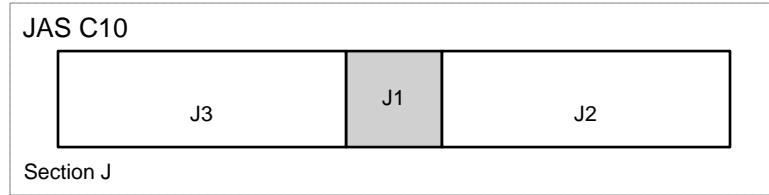
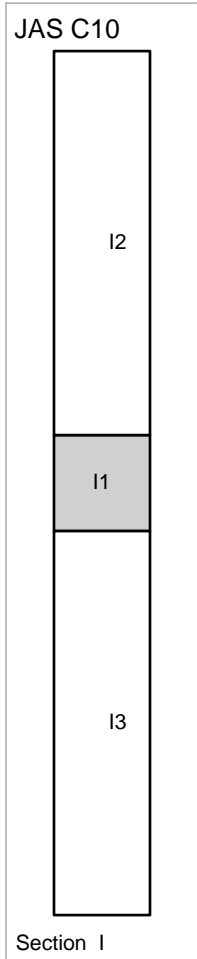

©Susan R. Gatewood, 1997-present

Jane's Block...



My Block...



C11...

Difficulty Medium

Pieced

Number of Pieces = 16

When I did this block I pieced it.

But, looking back on it now, I think it would have been easier to appliqué the shapes to a square of the print fabric then sew it together, like a four-patch, and then add the borders.

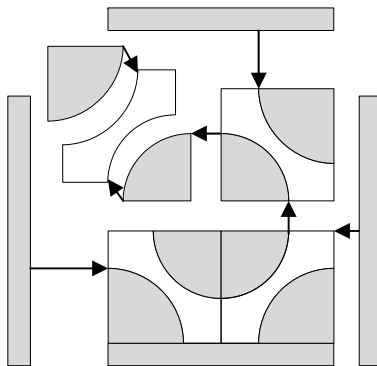

JAS C-11

Drafted by Susan R. Gatewood, in Electric Quilt

Key Block (77/100 actual size)

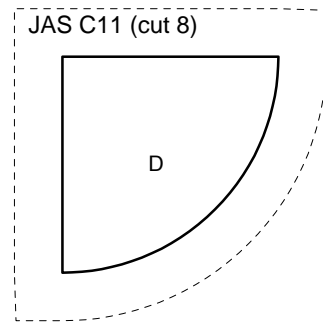
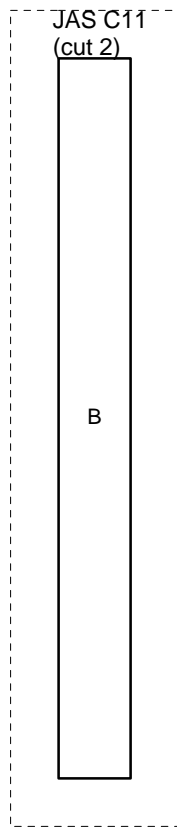
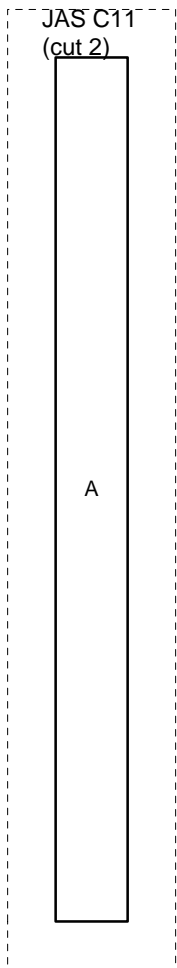
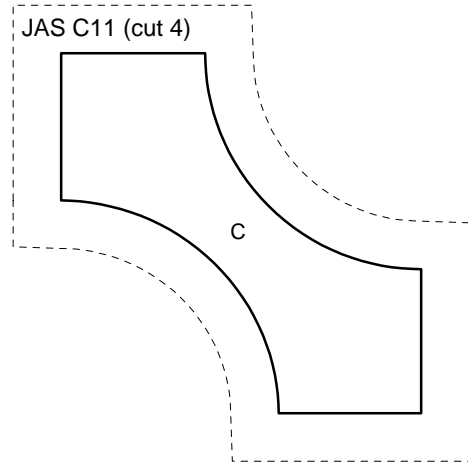
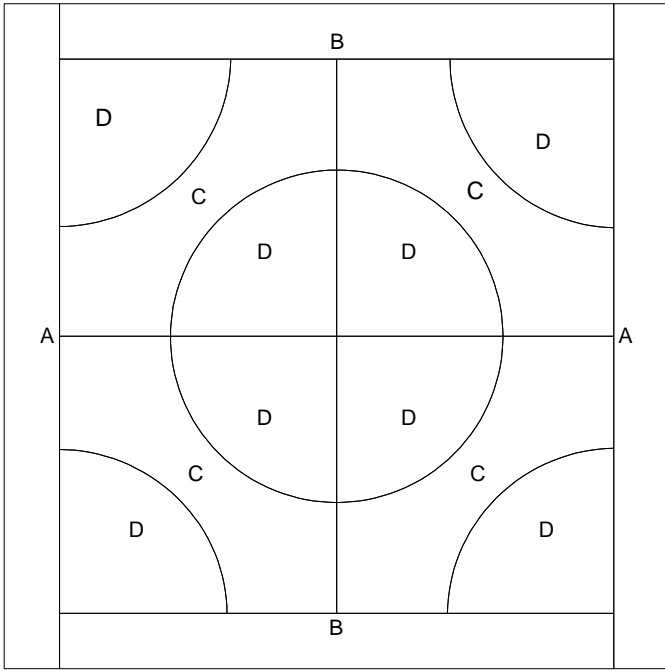

Jane's Block...

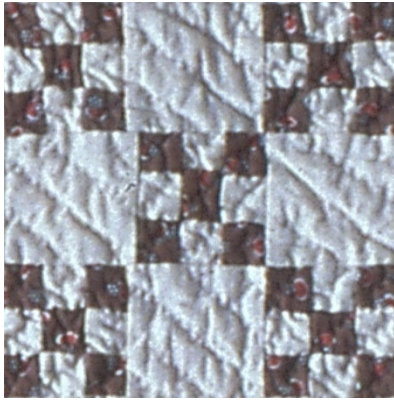

My Block...

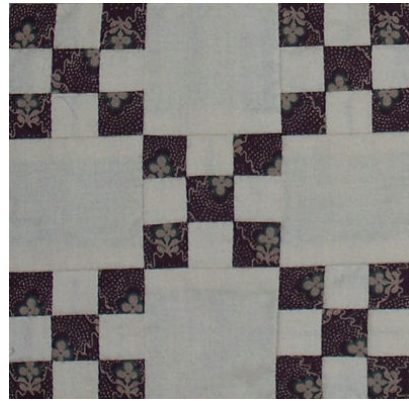

C12

Difficulty Easy

Pieced

Number of Pieces = 49

This block can be stripped pieced. Just think of creating tiny nine-patches. The pattern page will give you the directions for rotary cutting.

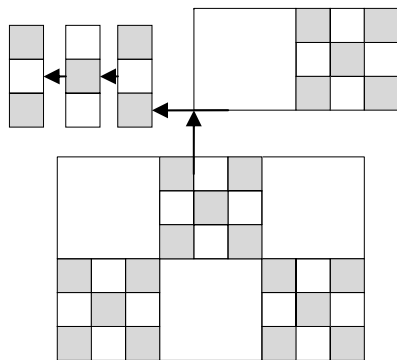

JAS C12

Drafted by Susan R. Gatewood, 1997

Key Block (11/20 actual size)

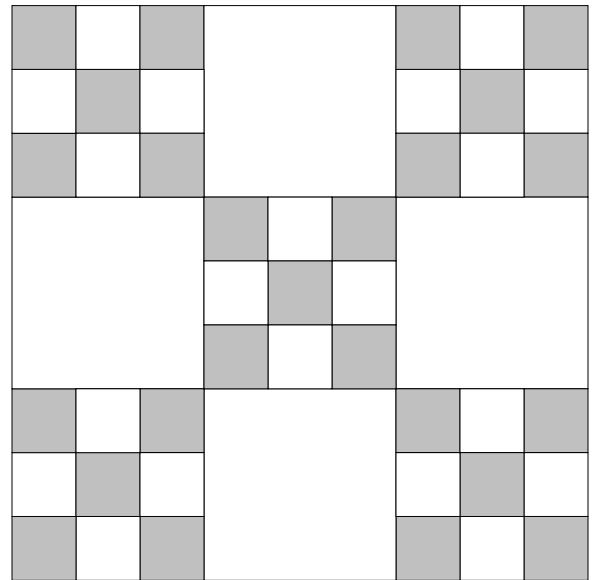
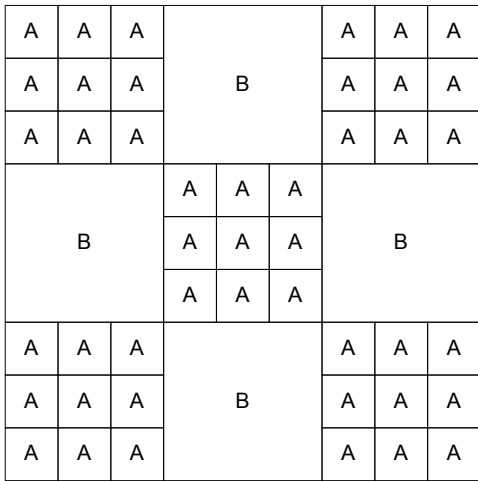

Cutting Diagrams

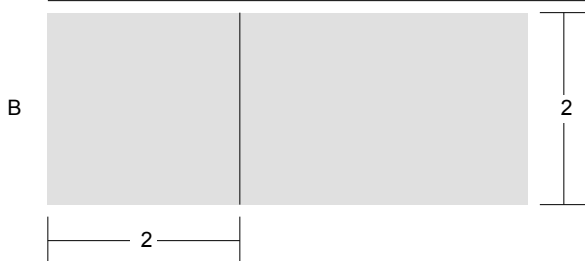
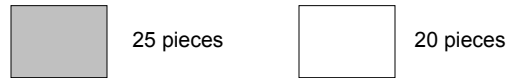

©Susan R. Gatewood, 1997-present

Jane A. Stickle, Sampler Quilt C-13

Jane's Block...



My Block...



C13

Difficulty Medium

Paper Foundation

Number of Pieces = 25

This block is again noted as medium difficulty, but looking at it in pieces, and working on just a piece at a time, will make it very easy. Just trust yourself, and each block will help you increase your abilities. You will learn so much while you are working on this quilt.

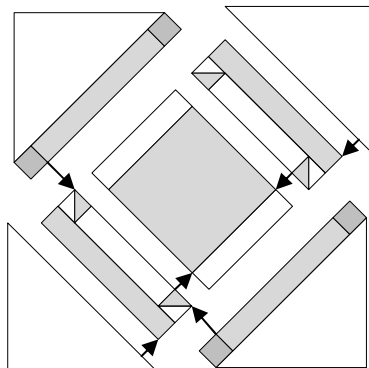

JAS C13

Drafted by Susan R. Gatewood, 1997

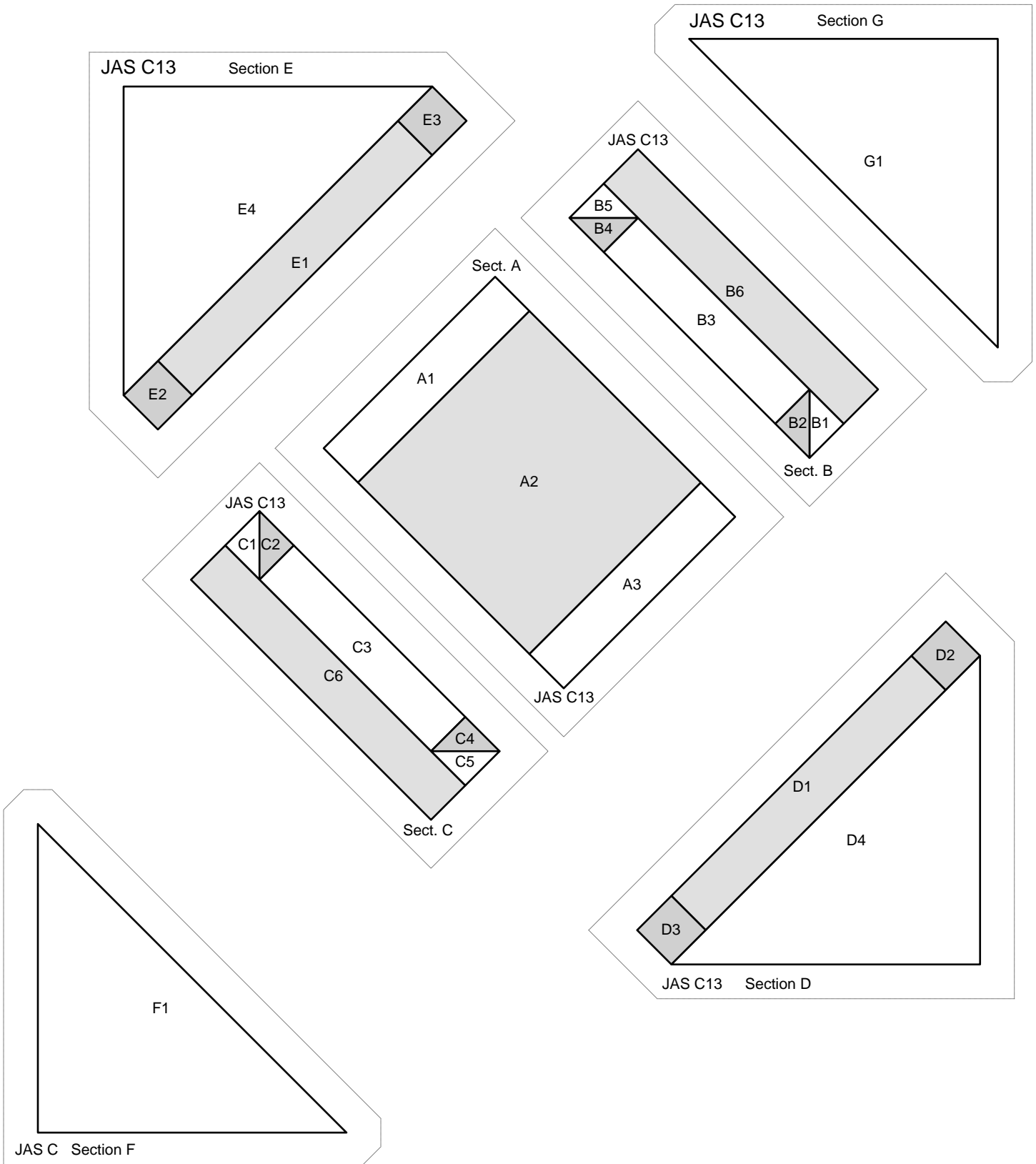

©Susan R. Gatewood, 1997-present